

U-Boards

Unitech Boards

CEMENT BOARDS AND ACCESSORIES



www.unitech-ikk.com
www.ikkgroup.com



UNITECH
For Building and Construction Materials

CEMENT BOARDS AND ACCESSORIES



Basket Trays & Accessories

Index

About UNITECH	4
U-Board Product Range	11
Decorative UV Coating Boards	23
Contact Information	32



**ABOUT
UNITECH**

Unitech Introduction

Unitech is a proud regional company providing building and construction solutions that empower the regions' construction industry for the past 40+ years. We have been successfully providing solutions through mastering our main business activities:



Design:

Provide Design & Engineering Solution to the construction sector, complying with international & local standards.



Manufacture:

Operating with Global Standards, we are widely recognized for our advanced light steel solutions and Hot-Dip Galvanization Facility.



Trade:

We are one of the region's largest Importer/Exporter of Building & Construction Materials

Unitech is an ISO QMS 9001:2015 certified company and is a member of the US Green Building Council. Our experienced teams and operations are present across the Middle-East North Africa regions (MENA) and Pakistan, giving us an extensive regional network that benefits our clients and partners. We are also present in Europe via our design and engineering office in Stuttgart.

For more information, please visit: www.unitech-ikk.com

Mission & Vision

Mission

We have the conviction to be the leader in building & construction industry through:

- Providing excellence in services with passionate & educated sales force
- Strengthen culture through unified sense of purpose
- Innovative product range which is customer centric
- Reputable and quality service company
- Attracting, engaging and retaining talent

Vision

To be the Customer's First Choice...

Our Strategy

Unitech's strategy continues to focus on accelerating its business throughout the region, to service the construction sector via superior products & solutions, backed up by a group of highly experienced people in the field. Unitech also aims to enhance its geographical presence in its areas of interest and where opportunities exist.

We combine a deep understanding of building and construction materials markets with a successful history of upgrading our products and developing our processes.

We have the qualified employees, the know-how and the products to service major construction projects, medium sized to mega projects taking in care our positive contribution to our societies.

We thrive towards excellence by acknowledging:



Customer Satisfaction



Partner and Supplier Relations



Employee Retention



Positive Influence on Society and Environment

Our Employees

We are a company that prides itself on its 'family' culture and we seek out high-caliber people. We are a company that has, at its core, a team philosophy that is clearly apparent each and every day - there is a real sense of being there for one another.

We believe in nurturing the skills of our team members and providing growing levels of responsibility. Our people bring unique skills, energy, expertise, experience and perspectives to our workforce.

Unitech's family of employees consists of experienced, well-motivated and dedicated team of engineers, technicians, sales executives and management staff. This team is committed to serve our customers, with the best solutions available in the market.

Our Journey

40+ Years of Excellence

Since 1979, having been set to become an independent company under the framework developed by Sheikh Isam Kabbani, Unitech started its journey of success with confidence and enthusiasm, hard work and care to detail and a commitment to become the best within its industry.

Its dedicated people could only imagine what the future could bring to this newly established entity. Unitech's journey of success has been marked with outstanding achievements and superior accomplishments. Year by year, Unitech has been acknowledged as the "First Choice for Building & Construction Material" by major construction consultants in the region, governmental authorities, well-known contracting and project development corporations.

We have obtained invaluable knowledge about the construction industry in general, providing specialized solutions to construction projects throughout MENA region. From a couple of outlets in Saudi Arabia, Unitech today is present all over the Kingdom and in several countries throughout the region providing its products and solution to various locations worldwide.



Est. 1979

THE BEGINNING

Unitech was established in the Western Region of KSA as a Sales Company selling basic construction material.

During the same year, another branch was established in the heart of the kingdoms capital, Riyadh.



1980 to 1989

AGE OF GREAT RISK

Unitech Dammam was open for business in the oil-rich eastern coast of Saudi Arabia.

Within these 10 years the idea of in-house manufacturing facility was born and Specialized Factory for Steel Products (SFSP) was established in Riyadh.



1990 to 1999

AGE OF GROWTH

Branches of Unitech were established in Makkah, Madina, Khamis Mushayt and Jubail.

The need to increase its range of products and the necessity to have production lines for mass production lead to the decision to move the SFSP Factory from Riyadh to Jeddah.

Pioneering Construction Since 1979

We are constantly evolving in order to become more flexible in our operations, more sustainable in our societies, and more innovative in conducting our business.

By delivering superior products tailored to the specific construction needs, ambitious solutions, and an outstanding customer service, we serve today's needs through developing tomorrow's markets.

Helping construction projects experience success is what fueled its days. Unitech is keen to continue offering superior products, a wide spectrum of solutions, governed by our top-notch management style.

Such aspirations require trust in our responsibilities. Our Responsibilities for the future and with this in mind we continue to target excellence with committed efforts.



2000 to 2015

AGE OF CONSTRUCTION BOOM

Qassim, Hofuf and Yanbu Branches were inaugurated in KSA and branches outside KSA were established in UAE, Egypt, Lebanon, Oman, Jordan and Germany in order to facilitate the construction boom in the Middle East.

During this period SFSP state of the art facilities were launched in DIC UAE and Unitech thrived, marking some of the best years in business.



2016 to 2019

AGE OF GREAT CHANGE

This period, marked the age of great change in order to align with the economic shift in the GCC and the world in general.

Company wide right sizing initiatives were taken especially in KSA to align with the kingdom's ambitious vision 2030 and during this period the upgraded SFSP state of the art facilities were launched in JIC 3 KSA.



2020 & Beyond

NEW FRONTIER

This period marks the expansion of Unitech into the South and Central Asian territories. We aim to cater these markets and play an active role in these countries development.

During 2020, Unitech Pakistan was officially inaugurated and marked the entrance of Unitech into Asian Market.

Our Manufacturing Arm

SFSP

SFSP is a leading manufacturer and fabricator of light steel construction products in the region, servicing the construction sector through its state of the art facilities which are spread all over the MENA region. Products of SFSP are manufactured from quality raw material according to the relevant international standards to meet all kinds of construction projects requirements, such as MEP, façade, blockwork & waste management systems.

Commitment to Quality

Our commitment to quality is clearly revealed in the way we do our business; our processes, our close interaction with our clients as well as the strict product inspection procedures. To achieve this, we have implemented quality systems & processes that are continually being improved to satisfy our customer's needs.

Product Development

Product development process is substantial to the success of our business. We leverage all resources to provide up-to-date reliable products, environmentally friendly, durable to withstand the toughest weather conditions. Our engineers are constantly testing the products, seeking to present a combination of performance and quality across all our product ranges.

For more information, please visit:
www.sfsp-ikk.com

Value Chain

Our value chain starts up with the quality of the raw materials and ends up in client satisfaction. Our business practices backed up by all technologically essential business elements are supported by an efficient logistics, warehousing and delivery system that maintains a valuable supply chain for products.

The value chain is integrated in our business module, giving us strength and preserving our good reputation gained through the past 4 decades.

Engineering Specialty

Our products development engineers integrate their vast knowledge to provide the perfect solution to projects within the required specifications and time-frame.

The products development department maintains highly skilled calibers with a dedication towards efficient and reliable solutions even in the most complicated cases where delicacy and skillful approaches are indispensable.

Design and Product Safety

Our design and engineering office in Stuttgart ensures our products comply with relevant European and international standards of fabrication, taking into attention the safety factors which govern the public safety of projects.

Sustainability and Responsibility

We are constantly working hard to reduce our environmental footprints while maintaining the high quality and safety standards. We have set our targets to become three times more efficient in the next 10 years. Our responsibility towards our stakeholders is valued through our positive contributions towards our colleagues, our business partners and our communities as well.

Our Design Office



UNITECH DEUTSCHLAND is a "Design & Engineering" Office. Unitech Germany support Unitech & SFSP operations through well-informed cadre of engineers. They help our customers from conception to the completion by delivering design, engineering and project management services.

Thanks to our multidisciplinary team in Unitech Germany and their expertise, we assist you in your ambition to develop your innovation, your engineering and your organization. Our goal is to serve our clients through these elements:

- Excellent in engineering ideas and solutions
- High quality in performance
- Firmness on meeting deadlines

U-BOARDS PRODUCT RANGE

Cement Boards and Accessories

U-Boards products are manufactured according to international standards. Following is the U-Boards-Products Range:

Fiber Cement Boards

Fiber cement boards are manufactured from cellulose fiber, portland cement, quartz sand, additives and water; It is non asbestos, formaldehyde, benzene and other harmful substances and with excellent physical and chemical characteristics.

These boards are non combustible, fire and water resistant, green and environmental friendly, highly efficient and energysaving.

Magnesium Oxide Boards

These boards are used in place of traditional gypsum drywall as wall and ceiling covering material and sheathing. It is also used in a number of other construction applications such as: Fascias, Soffit, Shaft-Liner & Area Separation, Wall Sheathing and as tile backing (backer board) or as substrates for coatings and insulated systems such as Finish Systems.

It is suitable for a wide range of general building uses and for applications that require fire resistance, mold and mildew control, as well as sound control applications and many other benefits. Magnesium oxide board are available in various sizes and thickness. It is not a paper faced material.

Calcium Silicate Boards

Calcium silicate board reinforced with selected cellulose fibers and fillers. It is 100% free from asbestos, sepiolite, inorganic fibers or formaldehyde. The board is versatile and suitable for use in a wide range of internal and semi exposed external applications in building construction projects.

Calcium silicate passive fire protection board being clad around steel structure in order to achieve a fire-resistance rating. It is an economical building board material with fireproofing perty to replace concrete or block wall for the construction of non load bearing elements.

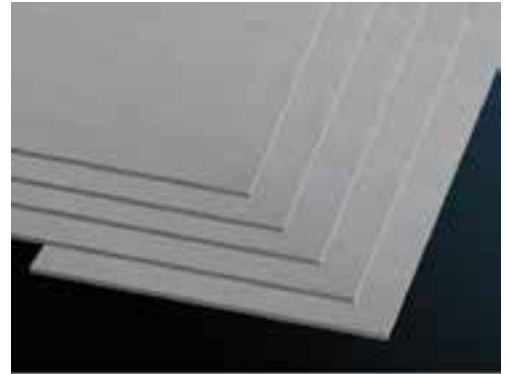



U-Boards products are manufactured according to international standards.

- 1- Fiber Cement Boards
- 2- Magnesium Oxide Boards
- 3- Calcium Silicate Boards
- 4- Decorative UV Coating Boards.

Product Range

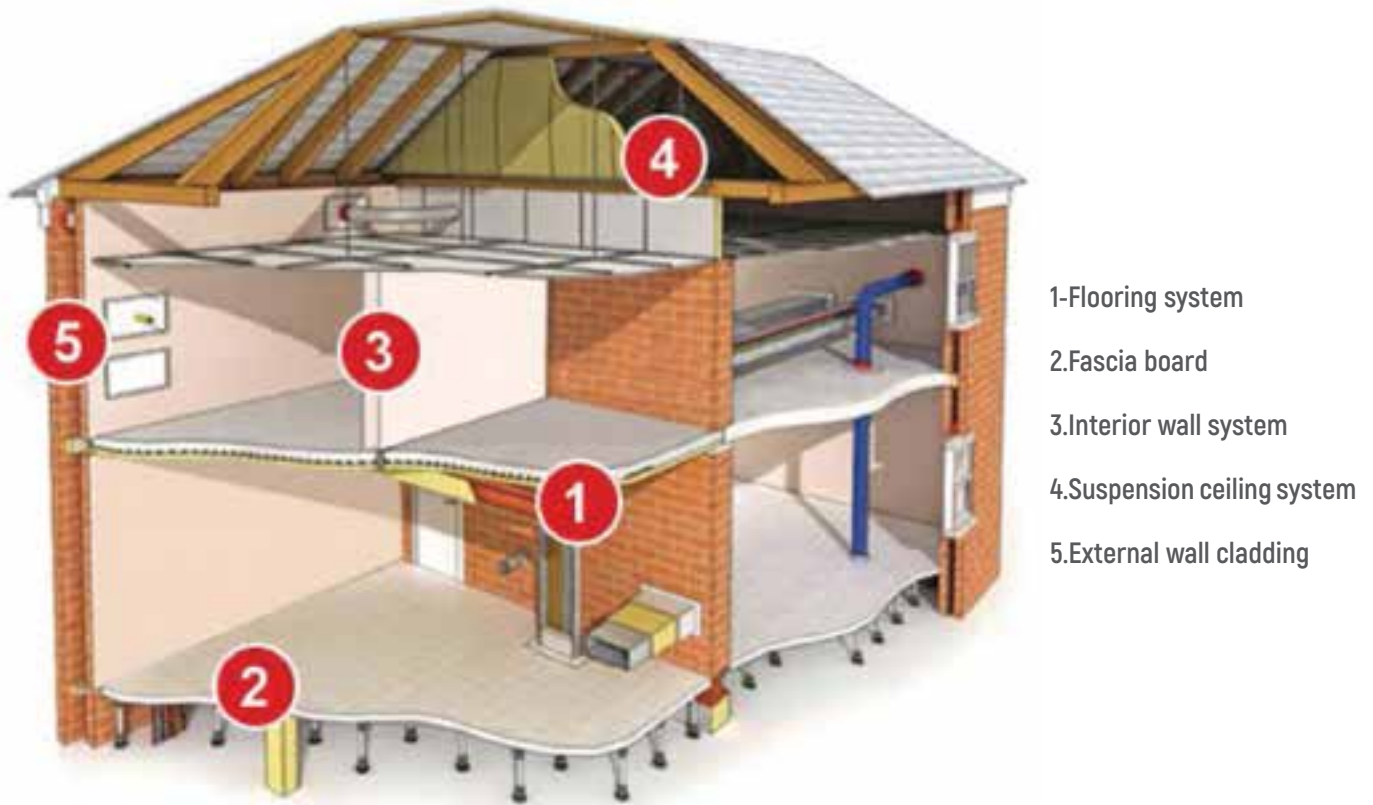

U-Boards in combination with different substrate framework like timber, steel and aluminum, offer unique advanced dry wall constructions, which leverage space utilization to the maximum along with substantial savings on time. It gives the architects major flexibility of changing designs with thermal and acoustic insulation besides being highly durable and ideal for residential, commercial and industrial usage.

U-Boards are preferred by many applicators as a base for directly applied finishes, it can be applied as wall cladding, wall partitioning and decorative wall in all types building especially where needs speedy construction, clean and hygiene such as schools and hospitals .

International Standards

- ASTM E84 , E119
- BS EN 12467
- SGS Certificate
- CE Certificate
- AS 1530.1-1994 Test Report
- AS/NZS 2908.2:2000
- BS Class A 476

Areas of Application:

- False Ceiling
- Internal Walls - Half Height/Full Height
- Internal Wall Lining
- External Wall
- Eaves and Staff Lining
- Bathtub and Swimming pools



- Interior Wall System

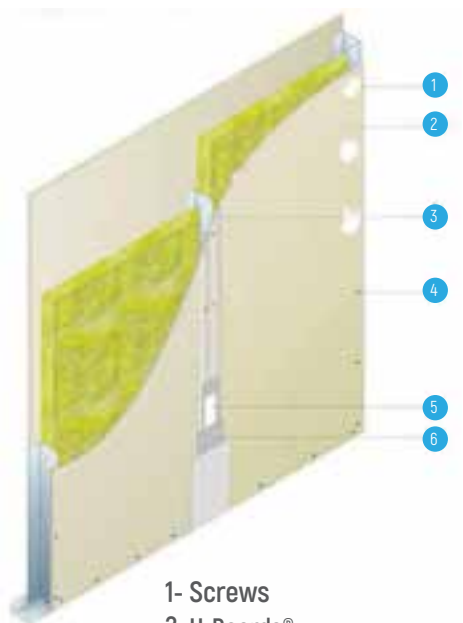

- 1- Screws
- 2. U-Boards®
- 3. C Stud
- 4. Screws
- 5. Jointing Tape
- 6. Wall Filler

- External Wall System

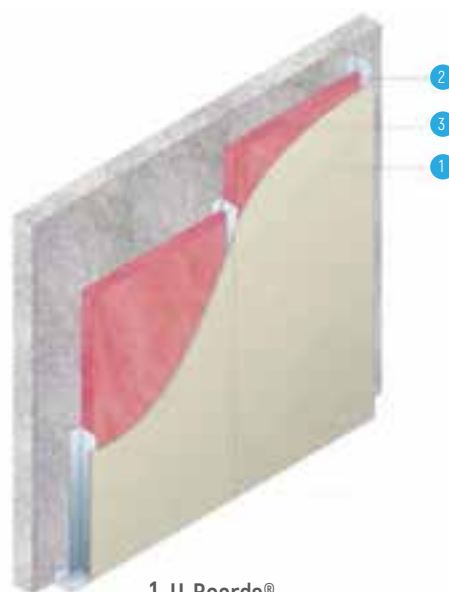

- 1. U-Boards®
- 2. C Stud
- 3. Wall Foundation

U-Boards Dimensions and Weights

Thickness	Width	Length	Weight
U-Boards Middle Density (Interior Usage)			
4 mm	1220 mm	2400 mm	17.79 Kg
6 mm	1220 mm	2400 mm	26.69 Kg
8 mm	1220 mm	2400 mm	35.58 Kg
9 mm	1220 mm	2400 mm	40.03 Kg
10 mm	1220 mm	2400 mm	44.48 Kg
12 mm	1220 mm	2400 mm	53.38 Kg
16 mm	1220 mm	2400 mm	71.17 Kg
U-Boards High Density (Exterior Usage)			
4 mm	1220 mm	2400 mm	21.21 Kg
6 mm	1220 mm	2400 mm	31.82 Kg
8 mm	1220 mm	2400 mm	42.43 Kg
9 mm	1220 mm	2400 mm	47.73 Kg
10 mm	1220 mm	2400 mm	53.03 Kg
12 mm	1220 mm	2400 mm	63.64 Kg
18 mm	1220 mm	2400 mm	94.15 Kg
20 mm	1220 mm	2400 mm	102.62 Kg
30 mm	1220 mm	2400 mm	153.93 Kg

* Different sizes are available upon request.

FIBER CEMENT BOARDS

Fiber cement boards are manufactured from cellulose fiber, portland cement, quartz sand, additives and water; It is non asbestos, formaldehyde, benzene and other harmful substances and with excellent physical and chemical characteristics. These boards are non combustible, fire and water resistant, green and environmental friendly, highly efficient and energy-saving.

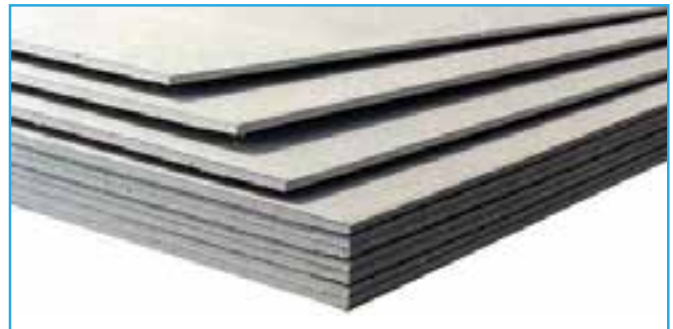

Features and Benefits of U-Boards

Surface	Although U-Boards are suitable for either mastic or thin-set mortar applications, the following is offered as a guide: – Smooth side for mastic applications; increases adhesive coverage. – Textured surface enhances bonding, reduces tile slip with mortar applications
Dimensional Stability	– Low thermal and hygrometric expansion helps prevent cracking – Will not swell, soften, decay, delaminate or disintegrate in water
Fire-Resistance	– Non combustible panel – 2-hour fire- resistance rating
Easy Installation	– Easy to cut and fasten
Convenient Sizes	– Different sizes are available depending on job requirements
Versatility	– Provides a smooth, sound base for glass and ceramic mosaics; ceramic and quarry tile; lugged tile; thin stone tile; and thin brick



COMPOSITION / INGREDIENTS	
Ingredient	Percentage of range (%)
Portland Cement	34%
Aluminum Oxide	4%
Lime	4%
Quartz Powder	38%
Water	8%
Cellulose fiber	12%

Tolerance	
Length to tolerance	+/- 5mm
Width tolerance	+/- 5mm
Thickness tolerance	+/- 0.3mm
Diagonal tolerance	+/- 5mm



Production Process

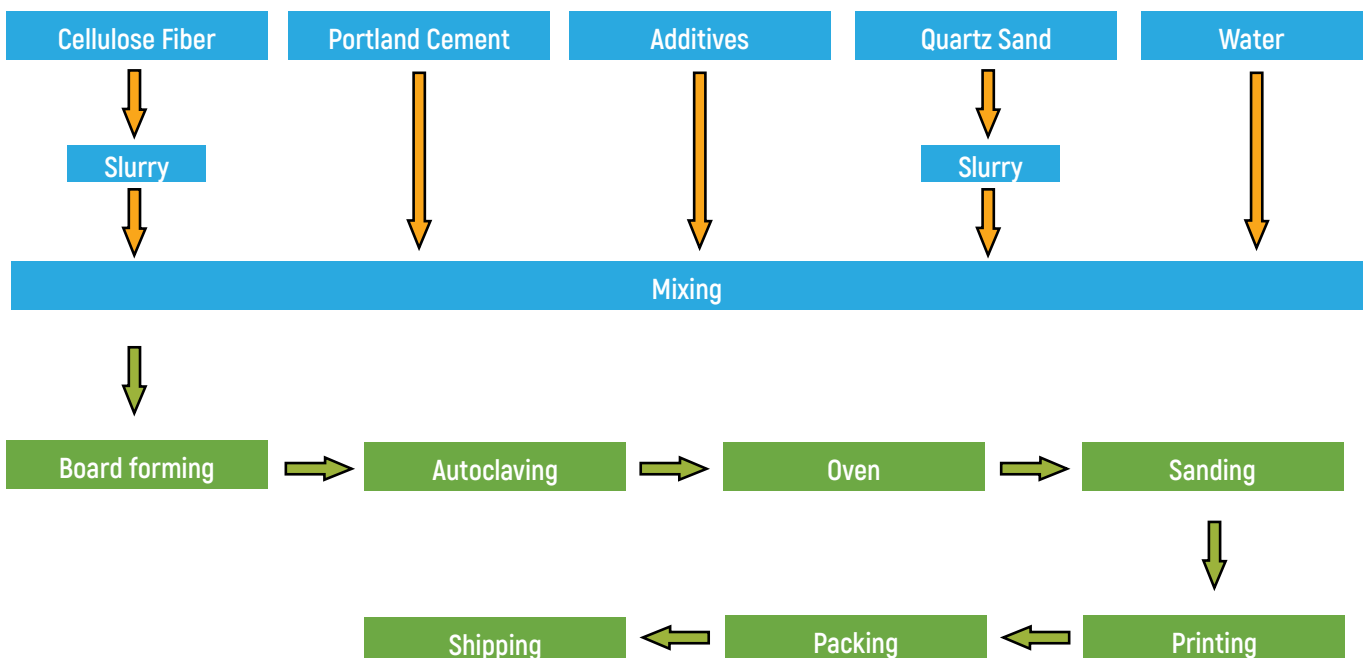

Technical Data

Size	1200 x 2400 mm
Density	> 1200 kg/m ³
Moisture content	≤10%
P.H. Value (Acid-base)	8 - 9
Corrosion resistant	> 3000 hours in salt fog test
Flexural strength	> 1691-gf/cm ²
Impact strength	71 Kg/m ² (8mm)
Adhesion bond strength	7.9 Kg/m ² (10mm)
Screws withdraw strength	0.9-1.0N
Fire resistance	up to 2 Hours (ASTM E84, E119, BS EN 12467 , part 4, part 7, part 22)
	up to 3 hours according to BS Class A 476 , part 6 -part 7 (Upon Request)
Length variation due to water absorption	0.06%
Thermal conductivity at 50 °C	≤0.21/W.mK
Water absorption	≤32%
Asbestos content	Not detected
Formaldehyde content	Not detected
Radioactivity	GB6566- 2001 A Class
Service temperatures	-40-140 °C
Sound insulation	27db (6mm)
Maintenance	Requires low maintenance and fewer resources for replacement
Workability	Easy workability
Service Duration	25 years



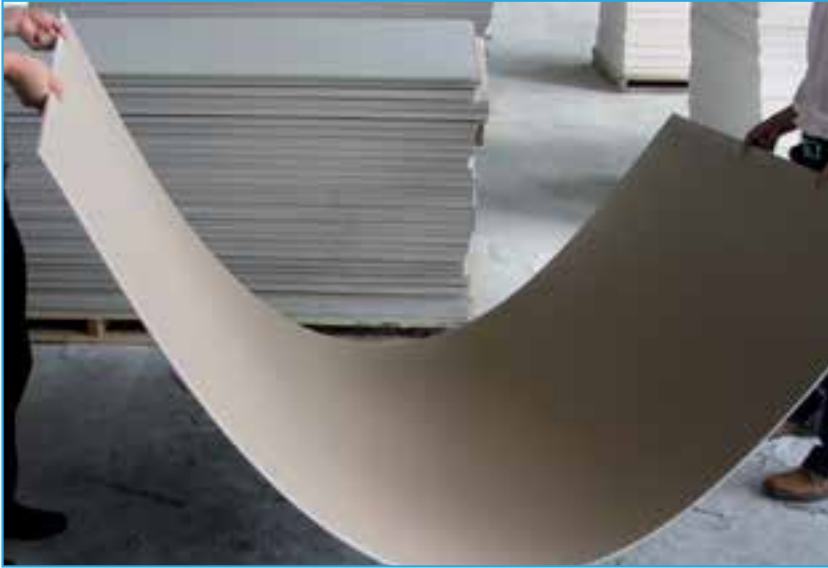

Magnesium oxide boards are used in place of traditional gypsum drywall as wall and ceiling covering material and sheathing. It is also used in a number of other construction applications such as: fascias, soffit, shaft-liner & area separation, wall sheathing, and as tile backing (backer board) or as substrates for coatings and insulated systems such as Finish Systems.

It is suitable for a wide range of general building uses and for applications that require fire resistance, mold and mildew control, as well as sound control applications and many other benefits.

Magnesium oxide board are available in various sizes and thickness. It is not a paper faced material. It generally comes in light gray, white or beige in color.

Tolerance	
Length to tolerance	+/- 5mm
Width tolerance	+/- 5mm
Thickness tolerance	+/- 0.3mm
Diagonal tolerance	+/- 5mm

COMPOSITION / INGREDIENTS	
Ingredient	Percentage of range (%)
Magnesium Oxide	34%
Magnesium Chloride	4%
Wood Chips	4%
Perlite	38%
Small Glass Cloth	8%
Additives	12%



Technical Data

Raw Materials	MgO, MgCl, Perlite, Fiberglass, non-woven fabrics
Density	Range from 0.8 to 1.15 g/cm ³
Compression Indentation	No residual deformation was noted following loading and the rest period
Nail Head Pull	12mm = 174.8 lbt C1325
Non-Combustible	ASTM E136, E84-05. ASTM E119
Elongation (Tensile Strength)	> 1.97N/mm ²
Sound Insulation Value	55 dB {12 mm thickness}
Heat Insulation Value	0.139W/mk
Pressure Resistance (Impact Strength)	23N/mm ²
Flexural Strength	> 580 psi, AC-386
Resistance to Mold and Mildew	ASTM D-3273
Toxicity Testing	non-toxic and is carcinogen and silica free
Structural Performance	ASTM E330 and AC386
Water Resistance	after 24 hours test, there wasn't water percolation or water drop on, the back side 12mm
Flame Spread	4.7
Smoke Spread	27



Safety:

Magnesium oxide board is formulated without asbestos or sepiolite or any other inorganic fibers. When using power saws or sanders in a confined space, dust extraction equipment is recommended to control dust levels.

Magnesium oxide board is designed for non-load bearing construction. Horizontal boards or ceiling panels shall not be walked on as they are not designed to take additional loads between supports; if there is a risk of this occurring, warning noticed should be displayed.

Fixers shall ensure to work from adequate and safe platforms where necessary.



Calcium silicate board reinforced with selected cellulose fibers and fillers. It is 100% free from asbestos, sepiolite, inorganic fibers or formaldehyde. The board is versatile and suitable for use in a wide range of internal and semi exposed external applications in building construction projects.

Calcium silicate passive fire protection board being clad around steel structure in order to achieve a fire-resistance rating.

It is an economical building board material with fireproofing property to replace concrete or block wall for the construction of non load bearing elements.

Tolerance	
Length to tolerance	+/- 5mm
Width tolerance	+/- 5mm
Thickness tolerance	+/- 0.3mm
Diagonal tolerance	+/- 5mm

Dimensions	mm
Thickness	6/9/12/-20
Widths	1200/1220
Lengths	2400/2440

COMPOSITION / INGREDIENTS	
Ingredient	Percentage of range (%)
Cement	34%
Aluminum Oxide	4%
Calcium Sulfate	4%
Quartz Powder	38%
Water	8%
Wood fiber	12%

Technical Data

Raw Materials	Cement lime, Quartz sand, Paper plug
Size	1200 x 2400
Density	> 1100 kg/m ³
Moisture content	≤12%
P.H. Value (Acid-base)	8-9
Corrosion resistant	> 3000 hours in salt fog test
Flexural strength	> 148<gf/cm ²
Impact strength	6.3 Kg/m ² (8mm)
Adhesion bond strength	7.0 Kg/m ² (10mm)
Screws withdraw strength	0.7-0.8 N
Fire resistance	up to 2 Hours (ASTM E84, E119, BS EN 12467 , part 4, part 7, part 22)
	up to 3 hours according to BS Class A 476 , part 6 -part 7 (Upon Request)
Length variation due to water absorption	0.08%
Thermal conductivity at 50 °C	≤0.21/W.mK
Water absorption	≤40%
Asbestos content	Not detected
Formaldehyde content	Not detected
Radioactivity	GB6566- 2001 A Class
Service temperatures	-40-140 °C
Sound insulation	26db (6mm)
Maintenance	Requires low maintenance and fewer resources for replacement
Workability	Easy workability



Safety:

Calcium silicate board is formulated without asbestos or sepiolite or any other inorganic fibers. When using power saws or sanders in a confined space, dust extraction equipment is recommended to control dust levels.

Calcium silicate board is designed for non-load bearing construction. Horizontal boards or ceiling panels shall not be walked on as they are not designed to take additional loads between supports; if there is a risk of this occurring, warning noticed should be displayed.

Fixers shall ensure that they work from adequate and safe platforms where necessary.

DECORATIVE UV COATING BOARDS

DECORATIVE UV COATING BOARDS

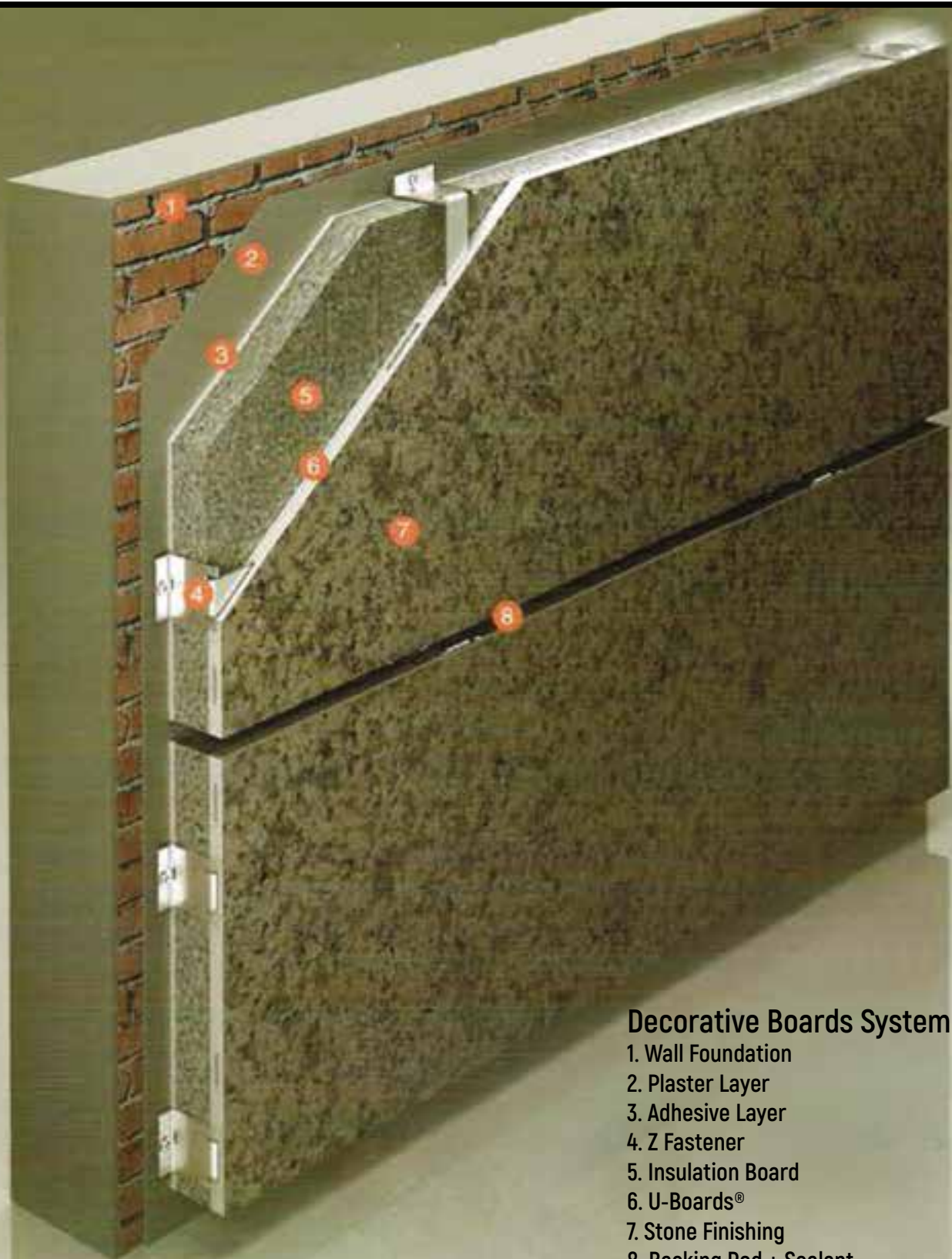

Decorative Boards System

1. Wall Foundation
2. Plaster Layer
3. Adhesive Layer
4. Z Fastener
5. Insulation Board
6. U-Boards®
7. Stone Finishing
8. Backing Rod + Sealant

UV Multicolor Grain Decorative Board

UV Multicolor Grain Decorative Board

UV Wood/Stone Grain Decorative Board is made from high density fiber cement board. The surface of the plate is coated with UV multicolor painting of any stone pattern, as smooth as mirror. The board is non-combustible, 100% non-asbestos and non-formaldehyde.



UV Coating Decorative Board

UV Coating Decorative Board is made from fiber cement board. The surface of the plate is coated with UV single color painting. The board is non-combustible, 100% non-asbestos, non-formaldehyde. The surface is treated with special waterproof treatment to decrease the possibility of surface pollution.

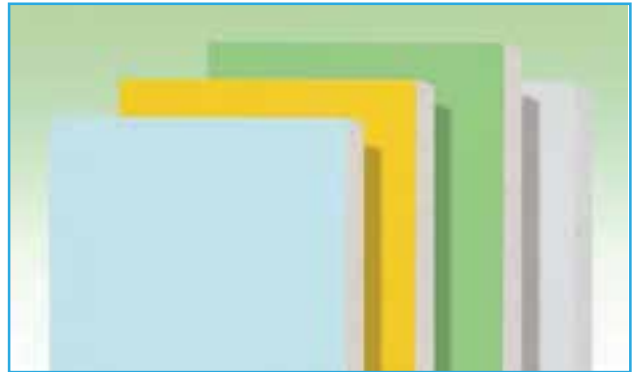

Fluorocarbon Coating Decorative Board

Fluorocarbon coating decorative board is made from high density fiber cement board. The surface of the plate is coated with fluorine resin. The major coating material has a service duration of 25 years. It is steadier having better properties than other paints.



Applications:

Can be used in the thermal insulation decoration of high-grade building's interior wall such as big markets, shopping malls, star-rated hotels, office buildings and industrial exhibition halls, etc. It is suitable for hospitals, schools, libraries and other building having a high requirements for fireproofing and noise control. It can be used for refurbishment and repairing of old buildings interior wall.



Technical Data

	1200 x 2400/1220 x 2440mm
Thickness	4 mm , 6mm, 9mm, 10mm. 12mm ,16mm
Density	> 1200 kg/m ²
Corrosion resistant	> 3000 hours in salt fog test
Hardness	> 0.8
Impact strength	71 Kg/m ² (8mm)
Adhesion bond strength	7.9 Kg/m ² (10mm)
Screws withdraw strength	0.9-1.0N
Fire resistance	up to 2 Hours (ASTM E84, E119, BS EN 12467 , part 4, part 7, part 22)
	up to 3 hours according to BS Class A 476 , part 6 -part 7 (Upon Request)
Thermal conductivity at 50 °C	≤0.21/W.mK
Service temperatures	-40-140 °C
Sound insulation	27db (6mm)
Service Duration	25 years

* Different sizes are available upon request.

Superior Performance:

1. Excellent Fire-Resistance Property

U-Boards are a fireproof board ,9mm reach up to 2 hours fireproofing

2. Superior Weathering Resistance

Corrosion resistance and Ultraviolet light chalking resistance

3. Easy Installation and Maintenance

Cutting and planning, can be done by some simple woodworking tools. flexible for designers as the installation work is easy , fast and cost saving.

4. Coating & Diversified Colors

With chemosynthesis treatment and film technology, the adhesion between the paint and panel becomes evener, having multiple colors. There is more space for your choice to the color with individuality.

5. Impact Resistance

Strong impact resistance and toughness . The coating layer cannot be crashed when it' s bent The panel cannot be damaged when in a strong windy and sandy condition.

6. Sound and thermal insulation.

Associated equipments for U-Boards' installation



CUTTING AND SAWING

Use Normal wood working tools such as traditional handsaw. For shaped cuts, Use a pad saw, keyhole saw or circular saw. Work with fair face upwards and support the board as cutting process progress. For power sawing, use a carbide or diamond tipped blade.



DRILLING

Use a hand drill or conventional hand held drill with high steel bits. Always support the board firmly behind the whole location,when drilling. Large holes can be with a tungsten carbide tipped hole drilling socket or by drilling a series of pilot holes and gently tapping out the center with a hammer.



PLANNING AND SANDING

Edges of the board can be planned or smoothed with plan, rasp or file. Sand with conventional papers.



CONCRETE NAILS

Concrete nails can be driven directly through the board without pre-drilling provided that they are at least 12mm from board edges. Galvanized wire nails are recommended. Do not use lost head nails or panel nails.

Fixing guides: From edge: 12mm minimum, from corner: 40mm minimum compressed air nailing or stapling equipment offers a fast and economical fixing method where large numbers of fixing are required or where production line techniques are being employed.

The nail /staple manufactures recommendations should be followed when selecting nail/staple types. Test the equipment and adjust the air pressure each time before commencing nailing operations.



FIXING

Boards shall be supported on all four edges and intermediate positions at centers not exceeding 610mm. Joints between boards should occur on the centers of the supports. Rust-proofing fixings should be used for all external applications or where conditions of high humidity or dampness are anticipated.



SCREWING

When screwing, do not countersink 6mm boards. Pre-drilling is not necessary. Use wood or self-tapping screws, screws should be at minimum 12mm from board edges and 50mm from board corners.

JOINTING

The stability of the boards allows butt joint to be used. Alternatively, board can be slightly apart and filled. Joints and crews holes can be filled and sanded to a smooth flat surface.



PAINTING

Conventional paints can be used. With water based paints. a diluted first coat should be used. For oil based paints, always use the proprietary primer / top coated systems as recommended by the paint manufacturer.



TILING

Minimum 9mm thick boards should be used with textured side out. Supports should be at 400mm centers maximum with cross noggins at traverse board joints. Countersink corrosion resistant screws should be used to fix the boards at 200mm centers. Tiles should be adhered to the board by proprietary adhesive in strict accordance with manufacturers' recommendations.



COMPATIBILITY

Boards are compatible with most common building materials, non-caustic and is resistant to corrosion, will not affect bituminous compounds; should be protected when in contact with un-anodized aluminum .



2. Handling and Storage

BOARDS LIFTINGS

Always lift boards off the board below, never slide board on board or drag the stack.



PROPER HANDLING

Always carry the boards vertically on it's edge . Do not stock on edge.



INCORRECT HANDLING

Never carry the boards horizontally. This may cause the board to be easily broken.

STORAGE

Boards should be stored under cover or in closed area on a flat base. If stored in an open area , the stack should be fully protected from weather conditions. If stored on racks, boards should be fully supported across the width.

STACKING

Boards are stacked a max of 900mm high on firm level ground. If two or more pallets are stacked, the stack height should not be over 3200mm.



Walls, Interior and Exterior - Steel Studs

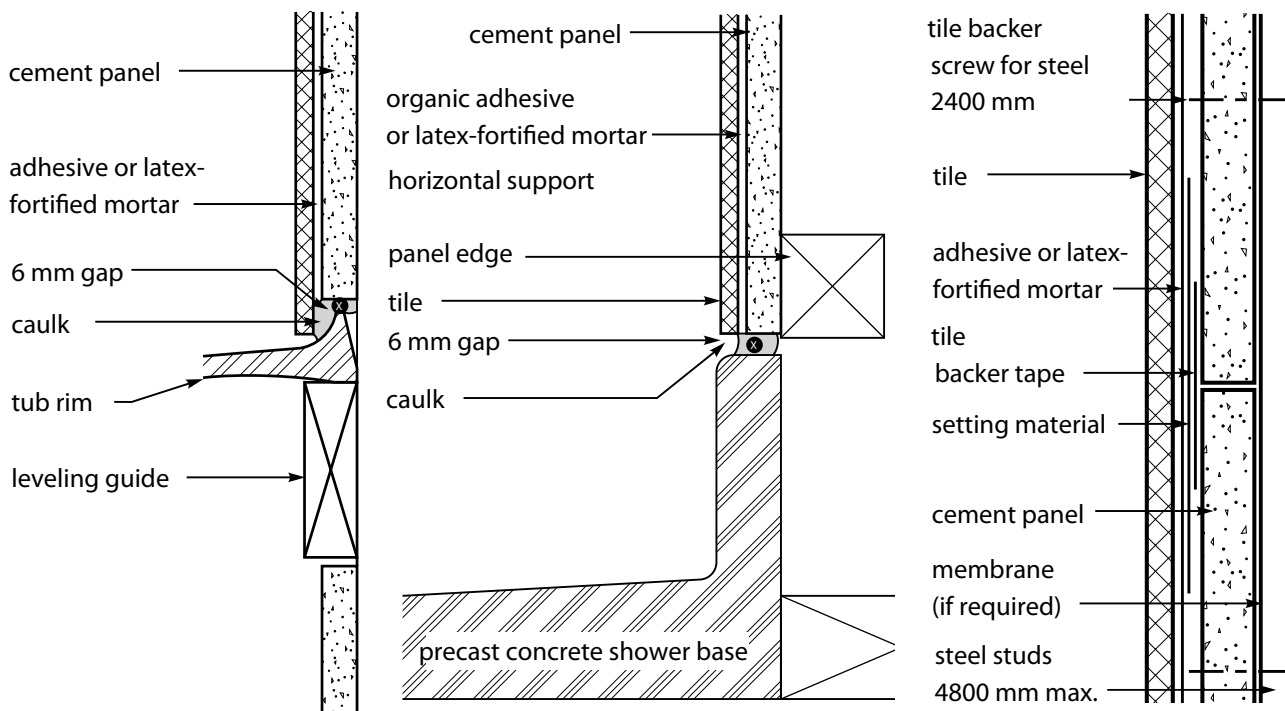

Fixture Attachment – Steel Framing

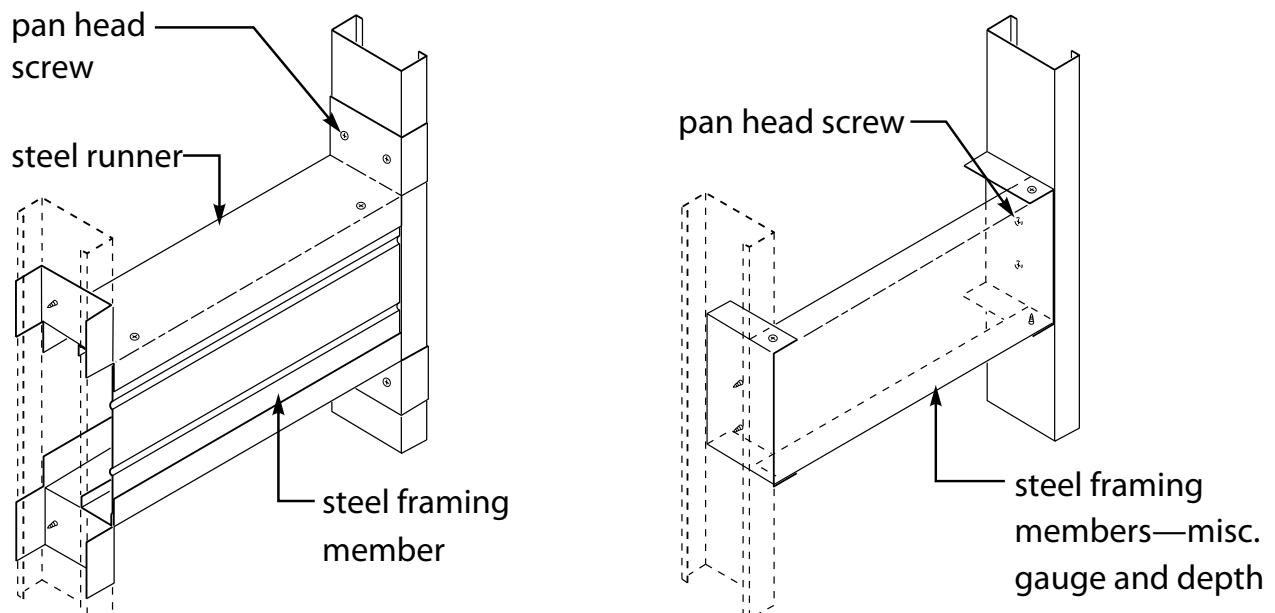

Tile Backer Screws for Steel Framing

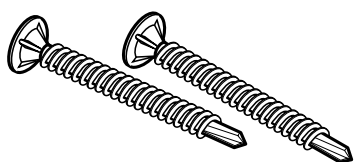

Hot-Dip Galvanized Roofing Nails

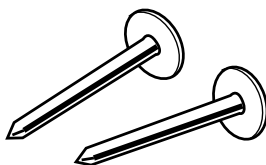

Resistant Tape

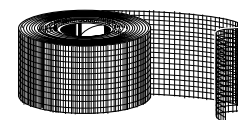

Typical bathtub installation

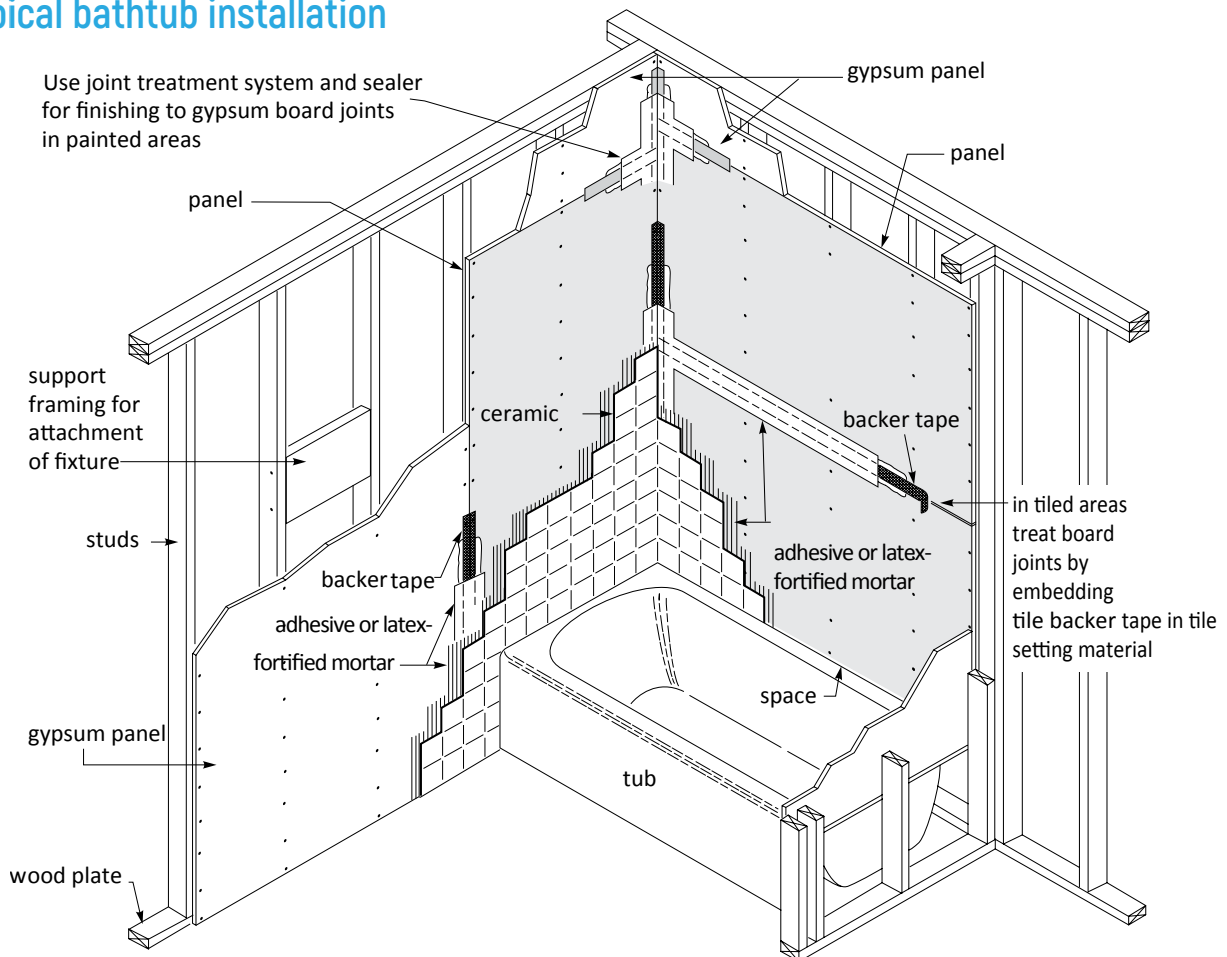

Typical swimming pool installation (tile or exterior finish)

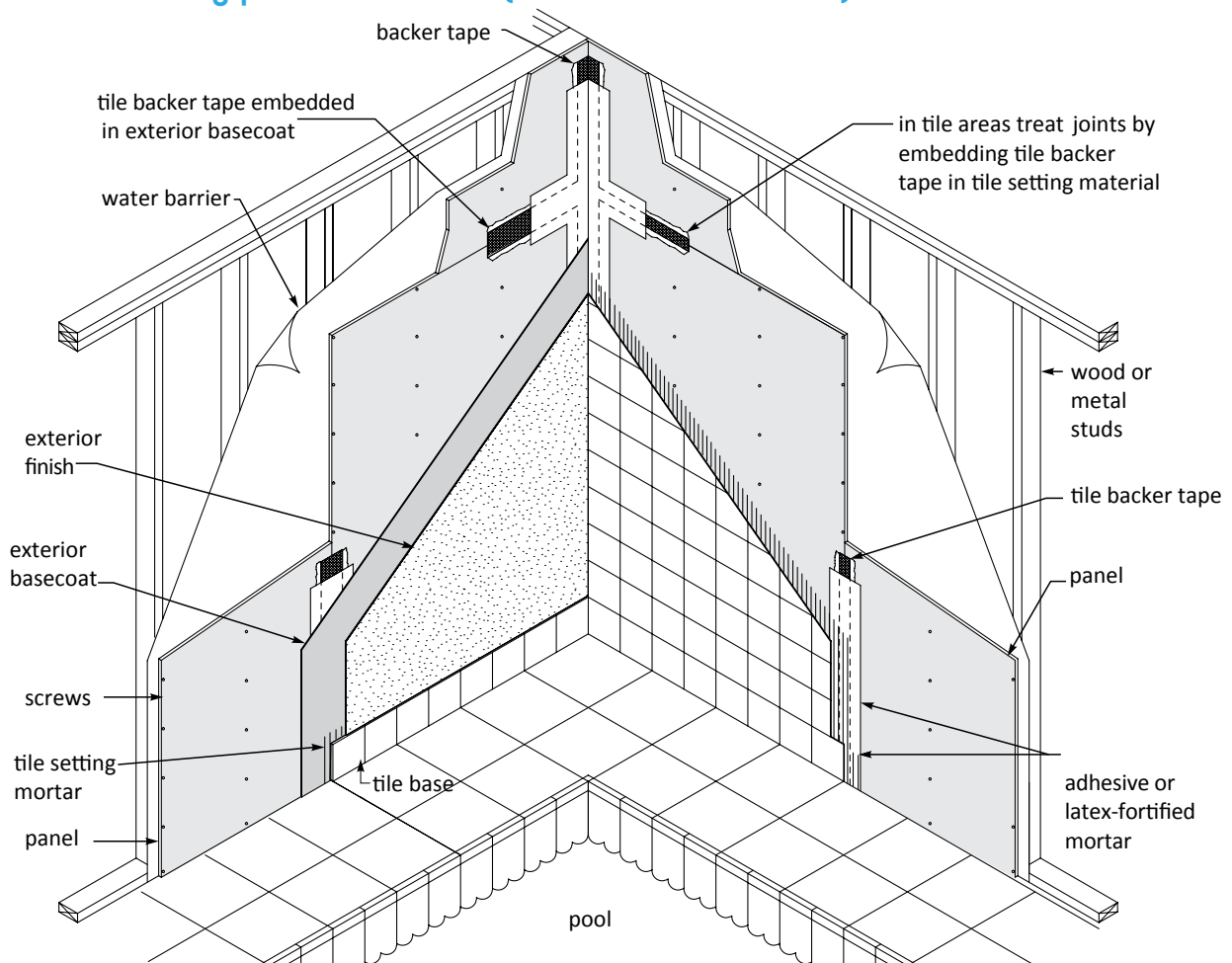

Good Design Practices

1. System Performance

U-Boards® systems. Our products shall not be used in a design or construction of any given structure without complete and detailed evaluation by a qualified structural engineer or architect to verify suitability of a particular product for use in the structure.

Information in this publication should be used only for **U-Boards®** systems, as physical properties of competitive products may vary. **U-Boards®** assumes no liability for failure resulting from the use of alternative materials or improper application or installation of **U-Boards®** systems as specified herein.

2. Expansion and Contraction

Wall surfaces should be isolated with surface control joints (sometimes referred to by the industry as expansion joints) or other means where: (a) a wall abuts a structural element or dissimilar wall or ceiling; (b) construction changes within the plane of the wall; (c) tile and thin brick surfaces exceed 4.8m. Surface control joint width should comply with architectural practices. Location of building control joints is the responsibility of the design professional/architect. Steel framing at building control joints that extend through the wall (with top and bottom runner tracks broken) should have 1-12 mm cold-rolled channel alignment stabilizers spaced a maximum of 1.5 m vertically. Channels should be placed through holes in the stud web of the first two adjacent studs on both sides of the joint and securely attached to the first adjacent stud on either side of the joint. Cement board should be separated at all surface and building control joints. Where vertical and horizontal joints intersect, the vertical joint should be continuous and the horizontal joint should abut it. Splices, terminals and intersections should be caulked with a sealant complying with architectural practices and sealant manufacturer recommendations. Do not apply tile or finishes over caulked sealed expansion joints.

3. Water Management

U-Boards® is vapor permeable and does not deteriorate in the presence of water. For interior applications, if a vapor retarder or waterproof construction is specified, a separate barrier shall be applied over or behind the **U-Boards®**.

4. Smooth Side/Rough Side

U-Boards® has a smooth side and a rough side. Although both sides of **U-Boards®** are suitable for either mastic or thin-set mortar applications, as a general guide, use the smooth side for mastic applications and the rough side for mortar applications.

5. Shadowing and Spotting

When the outside temperature differs considerably from the building's interior temperature, airborne dirt can accumulate on the colder regions of walls, causing "shadowing" or "spotting," particularly over fasteners and framing. This is a natural phenomenon that occurs through no fault in the products. Where temperature, humidity and soiling conditions are expected to cause objectionable blemishes, provide a thermal separation between the interior and exterior faces.

CONTACT INFORMATION

Contact Information

Sales Offices/Entities

KINGDOM OF SAUDI ARABIA unitech.ksa@ikkgroup.com

Jeddah
Tel : +966 12 627 8222

Mak kah/Taif
Tel : +966 12 541 1206

Mad inah
Tel : +966 14 8420959

Yanbu
Tel : +966 14 396 8885

Khamis Mushayt
Tel : +966 17 237 5929

Gizan
Tel : +966 17 321 6660

Riyadh
Tel : +966 11 292 8200

Qassim / Buraidah
Tel : +966 16 316 1122

Tabuk
Tel : +966 14 423 5203

Dammam
Tel : +966 13 859 0097

Hufuf
Tel : +966 13 530 1474

Jubail
Tel : +966 13 361 4390

UNITED ARAB EMIRATES

Dubai - Al Rashidiyah
unitech.dubai@ikkgroup.com
Tel : +971 4 2591 773

Abu Dhabi - Musaffah
unitech.auh@ikkgroup.com
Tel : +971 2 552 3393

BAHRAIN

Manama
unitech.bahrain@ikkgroup.com
Tel : +973 17 874 897

KUWAIT

Kuwait City
unitech.kuwait@ikkgroup.com
Tel : +965 2 2459 984

QATAR

Doha
info@unitech-qatar.com
Tel : +974 4451 3301

OMAN

Muscat
unitech.oman@ikkgroup.com
Tel : +968 24 591 006

LEBANON

Beirut
unitech.lebanon@ikkgroup.com
Tel : +961 1 858 277

EGYPT

Cairo 6th of October City
unitech.egypt@ikkgroup.com
Tel : +20 2 3820 6477

PAKISTAN

Lahore - Punjab
unitech.pakistan@ikkgroup.com
Tel : +92 42 32301578

SFSP Factories

SFSP - KSA
Specialized Factory for Steel Products
sfsp.jeddah@ikkgroup.com

3rd Industrial City / Jeddah
Tel : +966 12 637 4482

SFSP / UAE
SIGMA Factory for Steel Products
sfsp.uae@ikkgroup.com

DIC (Dubai Industrial City)
Tel : +971 4 818 1919

SFSP / EGYPT
Specialized Factory for Steel Products
sfsp.cairo@ikkgroup.com

6th of October City Giza
Tel : +20 2 3820 6477

SFSP / LEBANON
Specialized Factory for Steel Products / s.a.r.l
sfsp.lebanon@ikkgroup.com

Tanayel, Bekaa
Tel : +961 8 514 290

Engineering & Design

GERMANY
unitech.germany@ikkgroup.com

United Deutschland GmbH
Stuttgart, Germany
Tel : +49 711 6868 7222

Marketing & Multimedia

Multi-D s.a.r.l
multi-d@ikkgroup.com

Multi-D
Beirut, Lebanon
Tel : +961 1 841 155

